

# AIR HANDLING UNIT – DISCHARGE AIR TEMPERATURE CONTROL DX COOLING & TWO-POSITION HW HTG

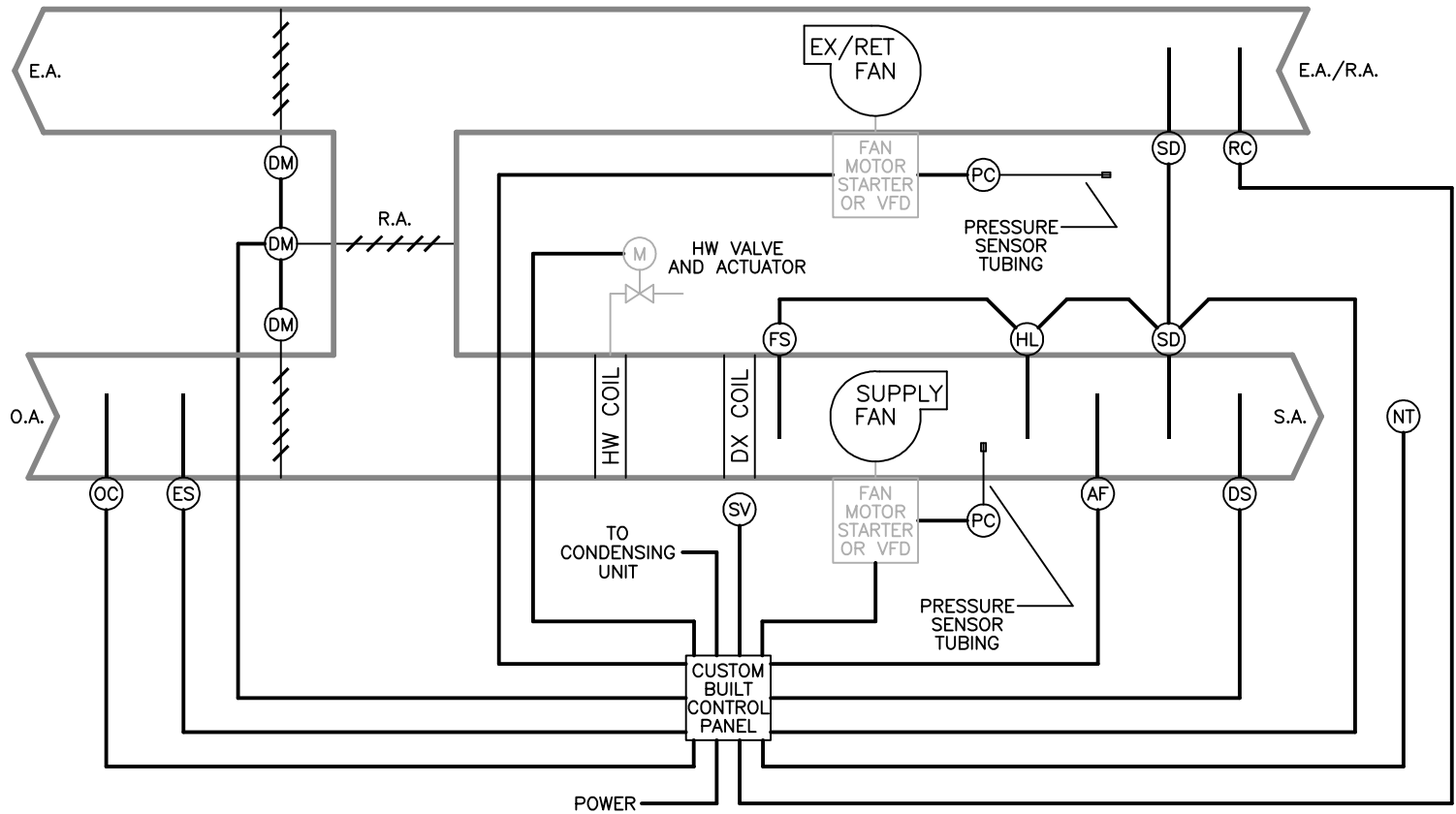

## DESCRIPTION

Built up air handling unit serving multiple zones with a discharge air temperature controller. The unit is equipped with DX cooling (with a remote condensing unit) and two position hot water heating. Cooling is controlled to maintain discharge air temperature. Heating is used for night setback and/or morning warmup only. The unit is also equipped with economizer controls. Typical applications include VAV systems (with fan speed control) and reheat systems (without fan speed control). Refer to valve sheets for hot water valve and actuator. Refer to starter sheet for starter descriptions, selections, and pricing. If this is for a VAV application, refer to VAV and fan powered box sheets for zone controls. If this is for a reheat application, refer to reheat coil sheets for zone controls.

## COMPONENTS

REFER TO PAGE 2 FOR NOTES

	NOTES	LABOR (hours)	MATERIAL (cost)
CUSTOM BUILT CONTROL PANEL	1 2 3 4	28.0	900.00
(NT) NIGHT SETBACK THERMOSTAT	5	2.0	40.00
(SD) DUCT MOUNTED SMOKE DETECTOR(S)	6 7	4.0 (6.0)	2 x 150.00 ea.
(FS) FREEZESTAT		2.0	120.00
(AF) AIR FLOW SWITCH	8	2.0	30.00
(SV) SOLENOID VALVE(S)	9	2.0 (3.0)	2 x 140.00 ea.
(DS) DISCHARGE AIR SENSOR		2.0	40.00
(HL) HIGH LIMIT STATIC PRESSURE CONTROLLER		2.0	60.00
(RC) RETURN AIR TEMPERATURE CONTROLLER	10	2.0	75.00
(DM) DAMPER MOTORS	11	12.0	750.00
(ES) ENTHALPY SENSOR		4.0	110.00
(OC) OUTSIDE AIR TEMPERATURE CONTROLLER		2.0	35.00
(PC) STATIC PRESSURE CONTROLLER FOR SUPPLY FAN	12 14	8.0	415.00
(PC) STATIC PRESSURE CONTROLLER FOR EXHAUST/RETURN FAN	13 14	8.0	415.00
<b>STARTUP AND COMMISSIONING:</b>	16 hours	<b>TOTALS:</b>	<b>83.0</b>
<b>ENGINEERING TIME:</b>	32 hours		
			<b>\$3570.00</b>

**AIR HANDLING UNIT – DISCHARGE AIR TEMPERATURE CONTROL  
DX COOLING & TWO-POSITION HW HEATING**

**NOTES**

- 1 Control system based on Honeywell W7100 discharge air temperature controller.
- 2 Control panel labor includes fabrication, mounting, and power, and wiring to the valve, starters (or VFDs) and condensing unit. All other wiring associated with the control panel is included in the labor factors of the devices wired back to the panel.
- 3 Labor included for wiring from the panel to the condensing unit based on the assumption that the condensing unit is within 100 feet of the panel.
- 4 Controls internal to the panel include time clock, discharge air electronic controller, relays, transformer, and damper positioning potentiometer.
- 5 Night setback thermostat required for night setback cycle. If the unit has no heating coil, and there are no sources of heat in the distribution ductwork, then the system does not have night setback capability. Delete this item.
- 6 No smoke detector required if the air handling unit CFM is less than 2000. Two smoke detectors required if the air handling unit CFM is greater than 15000. Otherwise, one detector required in the supply air duct.
- 7 Labor includes power wiring to the detector and interlocking the detector to the air handling unit control system. Labor does not include interlock to any fire alarm system.
- 8 Air flow switch or interlock to supply fan starter auxiliary contact necessary to prevent condensing unit operation when supply fan is not running. Labor factors are the same for either method. Delete material cost for air flow switch if starter auxiliary contact is used. For safety and redundancy, use both methods and double the labor factor.
- 9 For refrigeration circuits under 15 tons, use \$80.00 (ea.) for solenoid valve material cost. For circuits over 35 tons, use \$220.00 (ea.) for solenoid valve material cost.
- 10 Return air temperature controller required to terminate morning warmup cycle. If the unit has no heating coil, and there are no sources of heat in the distribution ductwork, then the system does not have morning warm-up capability. Delete this item.
- 11 Air handling system shown as having an exhaust/return fan and an exhaust air damper. Decrease the damper motors labor and material factors by 1/3 if there is no exhaust air damper.
- 12 Supply fan static pressure controller labor factor includes pressure tubing labor. High pressure tube is terminated in the supply air duct, 2/3 of the way down the main trunk. Low pressure tube (not shown) need not be terminated.
- 13 Exhaust fan static pressure controller labor factor includes pressure tubing labor. High pressure tube is terminated in a large open area of the space served by the exhaust fan. Low pressure tube (not shown) is terminated outdoors.
- 14 Two options for static pressure control of fans are variable frequency drives (VFDs) and inlet guide vanes (IGVs). The labor and material factors here include neither the VFDs nor the IGV actuators. For VFD control, refer to VFD quote for pricing. Starters are not required when VFDs are used. For IGV control, add cost of actuators (\$350.00 per) and labor required to mount the actuators (2 hours per).
- 15 Duct humidification is not considered here. Refer to duct mounted humidifier sheets.

		NOTES	LABOR (hours)	MATERIAL (cost)
CUSTOM BUILT CONTROL PANEL		1 2 3 4	28.0	900.00
(NT)	NIGHT SETBACK THERMOSTAT	5	2.0	40.00
(SD)	DUCT MOUNTED SMOKE DETECTOR(S)	6 7	4.0 (6.0)	2 x 150.00 ea.
(FS)	FREEZESTAT		2.0	120.00
(AF)	AIR FLOW SWITCH	8	2.0	30.00
(SV)	SOLENOID VALVE(S)	9	2.0 (3.0)	2 x 140.00 ea.
(DS)	DISCHARGE AIR SENSOR		2.0	40.00
(HL)	HIGH LIMIT STATIC PRESSURE CONTROLLER		2.0	60.00
(RC)	RETURN AIR TEMPERATURE CONTROLLER	10	2.0	75.00
(DM)	DAMPER MOTORS	11	12.0	750.00
(ES)	ENTHALPY SENSOR		4.0	110.00
(OC)	OUTSIDE AIR TEMPERATURE CONTROLLER		2.0	35.00
(PC)	STATIC PRESSURE CONTROLLER FOR SUPPLY FAN	12 14	8.0	415.00
(PC)	STATIC PRESSURE CONTROLLER FOR EXHAUST/RETURN FAN	13 14	8.0	415.00
<b>STARTUP AND COMMISSIONING:</b>			16 hours	
<b>ENGINEERING TIME:</b>			32 hours	
		<b>TOTALS:</b>	83.0	\$3570.00

# CONTROL VALVES – THREE-WAY BODIES, TWO-POSITION CONTROL HOT OR CHILLED WATER

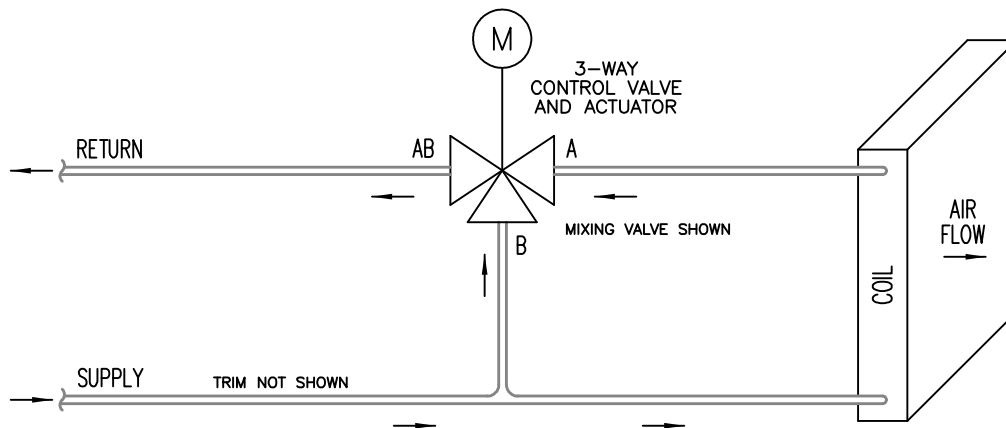

## DESCRIPTION

Three-way control valve with electric valve actuator suitable for two-position control of hot and chilled water. Typical applications include on/off control of water flow through the primary hot or chilled water coil of a fan coil unit, or on/off control of the morning warm-up coil of a built up air handling unit.

## VALVE PRICING TABLE

SIZE	GLOBE VALVES		BALL VALVES	
	SPRING RETURN	NON-SPRING RETURN	SPRING RETURN	NON-SPRING RETURN
1/2"	385.00	295.00	235.00	145.00
3/4"	410.00	320.00	270.00	180.00
1"	415.00	330.00	285.00	195.00
1-1/4"	440.00	350.00	295.00	200.00
1-1/2"	605.00	400.00	570.00	400.00
2"	655.00	430.00	610.00	435.00
2-1/2"	895.00	725.00	-----	-----
3"	945.00	770.00	-----	-----
4"	1080.00	905.00	-----	-----

## NOTES

- 1 Valve pricing based on Delta valves with Belimo 24 volt actuators.
- 2 Globe valves selected here have standard trim. Ball valves selected here have stainless steel ball and stems.
- 3 For two-position control, size the valve according to line size (example: 3/4" pipe gets 3/4" valve).
- 4 Three-way globe valves selected here are mixing valves. Three-way ball valves selected here are diverting valves (ball valves are diverting by design).
- 5 The valves selected here are "middle of the road". There are cheaper and more expensive alternatives.
- 6 For valve sizes up to 1", a "zone valve" is a much cheaper alternative. Refer to the HOT WATER REHEAT COIL – TWO-POSITION CONTROL guideline for zone valve pricing.

# DUCT MOUNTED HUMIDIFIER – STEAM GENERATING

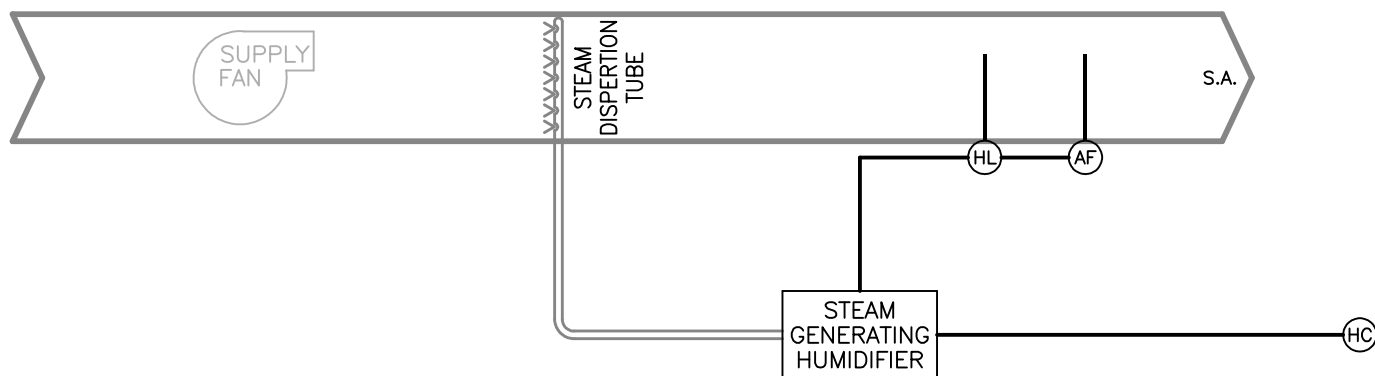

## DESCRIPTION

Duct mounted humidifier utilized in applications where there exists no steam supply system. Steam injection into the airstream is controlled by the humidifier control system operating in response to a signal from either a space or duct mounted humidity controller.

## COMPONENTS

		NOTES	LABOR (hours)	MATERIAL (cost)
STEAM GENERATING HUMIDIFIER		1	-----	-----
<del>(HC) SPACE HUMIDITY CONTROLLER (or)</del>		<del>2 3</del>	<del>4.0</del>	<del>-----</del>
(HC) DUCT HUMIDITY CONTROLLER		2 3	2.0	-----
(HL) HIGH LIMIT HUMIDISTAT		4	2.0	<del>85.00</del>
(AF) AIR FLOW SWITCH		4	2.0	<del>30.00</del>
<b>STARTUP AND COMMISSIONING:</b>	4 hours	TOTALS:	6.0	\$00.00
<b>ENGINEERING TIME:</b>	2 hours			

## NOTES

- 1 Refer to humidifier quote for humidifier pricing. Power for the humidifier is not included here, as it would fall under the category of "power wiring".
- 2 Control can be from either a space or duct mounted humidity controller. For single zone applications, space controlled humidification is preferable. For multiple zone applications, such as VAV or reheat systems, return air controlled humidification may be better suited for the application.
- 3 The space or duct mounted humidity controller is normally furnished with the humidifier. Refer to humidifier quote.
- 4 The high limit humidistat and the air flow switch are oftentimes furnished with the humidifier. Refer to humidifier quote, and delete the material cost of these items if this is the case.

# VAV BOX – COOLING ONLY

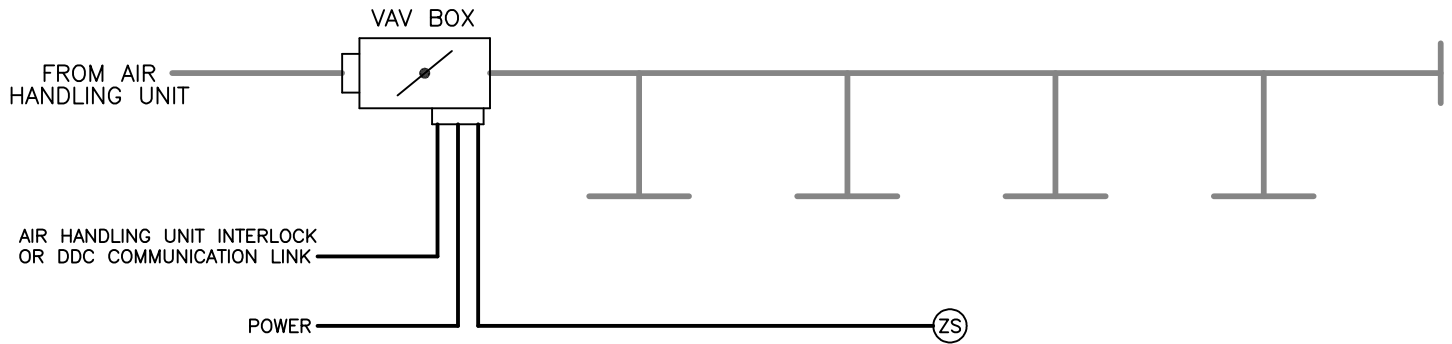

## DESCRIPTION

Cooling only VAV box served by an upstream air handling unit. The VAV box serves a single zone with a zone sensor in the zone. Air handling unit interlock and/or DDC communication link varies with the application.

## COMPONENTS

	NOTES	LABOR (hours)	MATERIAL (cost)
VAV BOX	1 2 3	2.0	110.00
(ZS) ZONE SENSOR	4	2.0	-----
<b>STARTUP AND COMMISSIONING:</b>	1/2 hour		
<b>ENGINEERING TIME:</b>	4 hours (per air handling unit)		
<b>TOTALS:</b>		4.0	\$110.00

x 7 BOXES = 28.0

## NOTES

- 1 The VAV box requires 24 volt power to it. Several options exist. One option is to use one 24 volt transformer sized for all of the boxes in the system, and run a 24 volt power loop to pick up all of the boxes. Another option is to have the VAV boxes furnished with 24 volt transformers. This option is desirable if the electrical contractor is providing 120 volts to each box location.
- 2 VAV box labor includes running a 24 volt power loop, and/or running an interlock or DDC link. If none of these has to be done, then delete the labor factor altogether.
- 3 VAV box material cost is not of the VAV box itself, but for a single 1 KVA 24 volt transformer (good for approximately 35 boxes). Delete this item if this option is not chosen (refer to note 1).
- 4 Zone sensor is furnished by the VAV box manufacturer. Refer to VAV box quote for unit costs.

# FAN POWERED BOX – COOLING WITH MOD. HOT WATER REHEAT

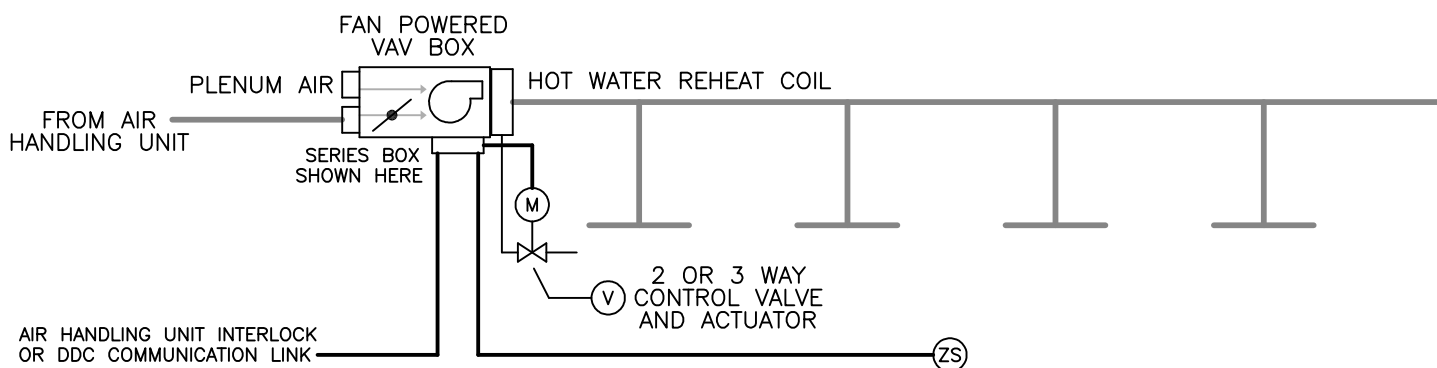

## DESCRIPTION

Fan powered VAV box with hot water reheat served by an upstream air handling unit. The fan powered box serves a single zone with a zone sensor in the zone. Air handling unit interlock and/or DDC communication link varies with the application. Reheat coil controller is factory furnished. Hot water valves are field wired. 120 volt or 277 volt power needed for the fan. 24 volt power for the VAV box controls and damper motor is provided by a factory furnished/installed transformer that utilizes the fan power source (120 or 277 volts) as its primary.

## COMPONENTS

	NOTES	LABOR (hours)	MATERIAL (cost)
FAN POWERED VAV BOX	[1] [2]	2.0	-----
(ZS) ZONE SENSOR	[3]	2.0	-----
(M) VALVE ACTUATOR	[4] [7]	1.0	110.00/60.00
(V) 1/2" VALVE BODY (or)	[5] [6] [7] [8]	-----	45.00
(V) 3/4" VALVE BODY		-----	50.00
<b>STARTUP AND COMMISSIONING:</b>		1.5 hours	
<b>ENGINEERING TIME:</b>		12 hours (per air handling unit)	
<b>TOTALS:</b>		3.0	\$155.00

x 16 BOXES = 48.0      \$2480.00

## NOTES

- [1] Power wiring to the fan (120 or 277 volts) is not included in the labor, and is assumed to be by the electrical contractor.
- [2] Labor for any air handling unit interlock or DDC communication link is included here in the VAV box labor. If there is no interlock or link, then delete this labor factor.
- [3] Zone sensor is furnished by the VAV box manufacturer. Refer to VAV box quote for unit costs.
- [4] The higher of the two material costs for the valve actuator is for 2–10 vdc control (used with Titus VAV boxes). The lower of the two costs is for floating control (used with Trane VAV boxes).
- [5] For modulating control, the valve body is sized according to flow rates and flow characteristics. Generally, this translates to a valve body size of 1 pipe size smaller than the line size.
- [6] Material costs shown for the valve bodies are for 3–way valves. Two–way valves are slightly cheaper.
- [7] Valve actuator and valve body can be furnished by the VAV box manufacturer for field installation. If so, delete material cost for these items, and refer to VAV box quote for unit costs.
- [8] There is no electrical labor associated with the valve body.

# HOT WATER BOILER – MULTIPLE BOILERS

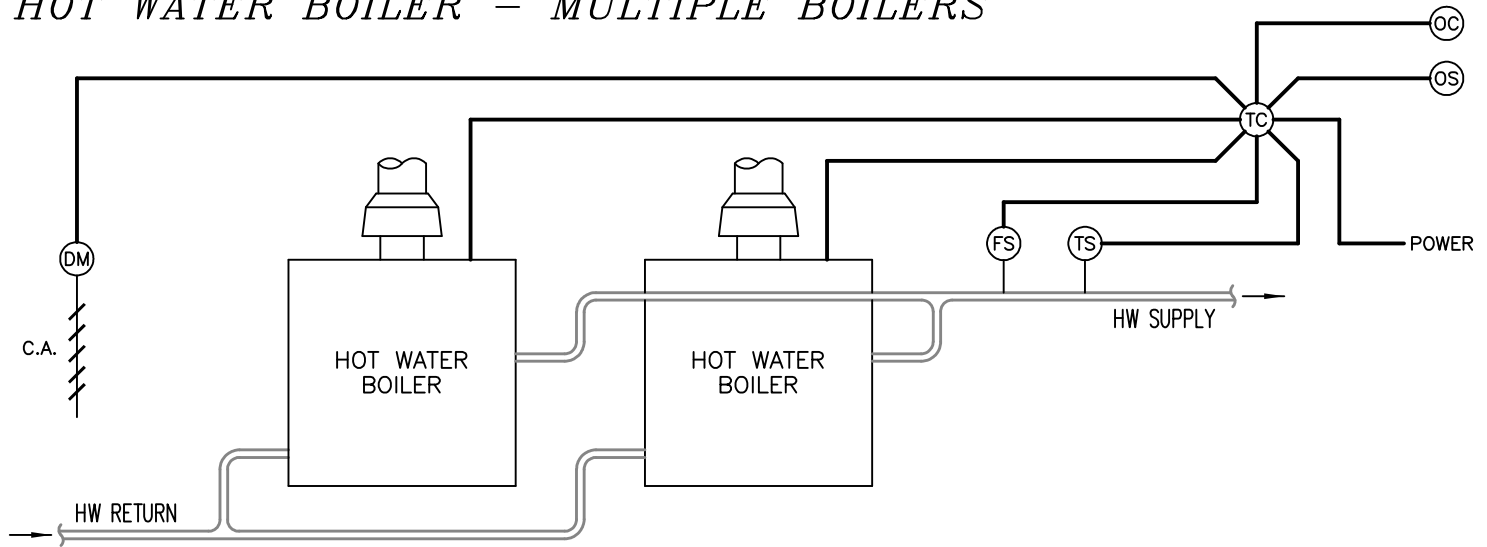

## DESCRIPTION

Multiple hot water boilers (single or dual stage) serving a common hot water system. The hot water temperature is controlled by firing the required number of boiler stages. Control is either straight temperature control, or reset control based on outside air temperature. Boiler control with the controller selected here is limited to four stages (two dual stage boilers, or up to four single stage boilers).

## COMPONENTS

		NOTES	LABOR (hours)	MATERIAL (cost)
(TC)	TEMPERATURE CONTROLLER (or)	1 2 3 4	10.0	170.00
(TC)	RESET CONTROLLER	1 2 3 4	10.0	300.00
(TS)	HOT WATER TEMPERATURE SENSOR (and)	5	2.0	30.00
(OS)	OUTSIDE AIR TEMPERATURE SENSOR	6	2.0	30.00
(FS)	FLOW SWITCH (OR LOW WATER CUTOFF)	7	4.0	85.00
(OC)	OUTSIDE AIR TEMPERATURE CONTROLLER	8	2.0	35.00
(DM)	DAMPER MOTOR	9	4.0	200.00
<b>STARTUP AND COMMISSIONING:</b>		10 hours	<b>TOTALS:</b>	<b>\$485.00</b>
<b>ENGINEERING TIME:</b>		6 hours		

## NOTES

- 1 In multiple boiler applications, it is desirable to control the boilers via a single controller, in lieu of using the boilers' factory installed operating controls.
- 2 This controller does not provide manual or automatic lead/lag operation of boiler stages. If this is desired (as well as other features), a much more expensive controller must be used, such as the Heatimer boiler sequencer (appr \$1700.00).
- 3 Determine whether the application calls for straight hot water temperature control, or hot water temperature reset control based on outside air temperature. Delete the controller not chosen.
- 4 Temperature controller labor includes mounting and power, and wiring to the boilers. All other wiring associated with the temperature controller is included in the labor factors of the devices wired back to the controller.
- 5 Hot water temperature sensor labor includes installation in the supply piping.
- 6 Delete this item if not using reset control.
- 7 Flow switch (or low water cutoff) labor includes installation in the supply piping.
- 8 Outside air temperature controller is necessary if it is desired to enable and disable boiler operation based on outside air conditions. Delete if not needed.
- 9 Delete this item if a motorized combustion air damper is not needed to fulfill the combustion air requirements. Double the labor and material factors if a ventilation damper is required in addition to a combustion air damper.

# PUMPING SYSTEMS – TWO PUMPS WITH MANUAL CONTROLS

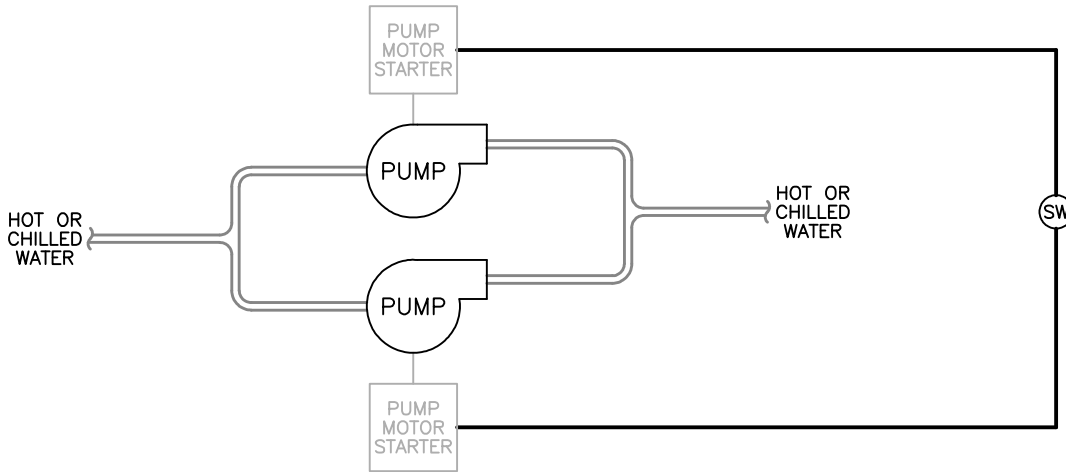

## DESCRIPTION

Pumping system for hot or chilled water applications. One pump or both pumps run, depending upon the application and how the pumps are sized. Pump motors are either three phase or single phase. Refer to starter sheet for starter descriptions, selections, and pricing. If pump motors are single phase, then delete the starters.

## COMPONENTS

		NOTES	LABOR (hours)	MATERIAL (cost)
<del>(SW)</del>	<del>"ON-OFF" OR SELECTOR SWITCH</del>	<del>[1]</del>	<del>2.0</del>	<del>10.00</del>
	<b>STARTUP AND COMMISSIONING:</b>		1 hour	
	<b>ENGINEERING TIME:</b>		1 hour	
		<b>TOTALS:</b>	0.0	\$0.00

## NOTES

- [1] Switch can be either an "ON-OFF" switch (if both pumps are to run at the same time), or a pump selector switch (if only one pump is to run at a given time).



# MOTOR STARTERS – THREE PHASE

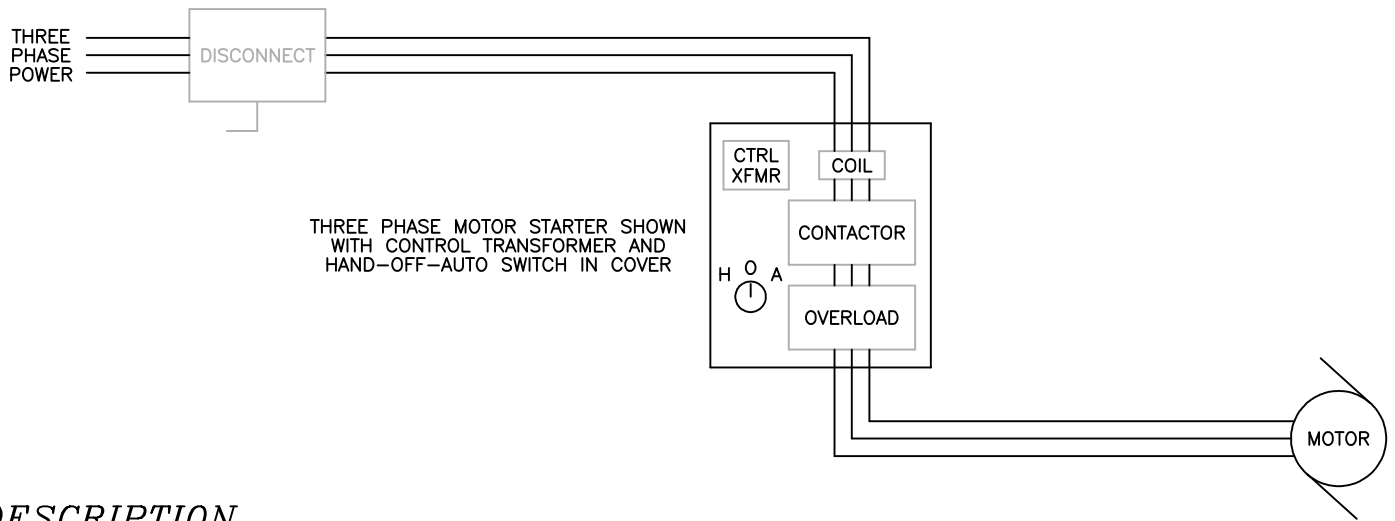

## DESCRIPTION

Three phase motor starter consisting of a coil/contactor and a solid state overload block, housed in a general purpose NEMA 1 or weatherproof NEMA 3R enclosure. Options include control transformer, selector switch or start/stop pushbuttons, pilot lights, and auxiliary contacts.

## STARTER PRICING TABLE

MAXIMUM HORSEPOWER AT			NEMA SIZE	HOUSED IN NEMA 1 ENCLOSURE	HOUSED IN NEMA 3R ENCLOSURE	ADD FOR CONTROL XFMR	ADD FOR SELECTOR SWITCH	ADD FOR PILOT LIGHT	ADD FOR AUXILIARY CONTACT
200 VOLTS	230 VOLTS	460 VOLTS							
3	3	5	0	213.00	277.00	142.00	42.00	80.00	32.00
7.5	7.5	10	1	240.00	303.00	142.00			
10	15	25	2	451.00	567.00	142.00			
25	30	50	3	736.00	873.00	295.00			
40	50	100	4	1634.00	2088.00	360.00			
75	100	200	5	3822.00	4984.00	406.00			
150	200	400	6	10728.00	12154.00	517.00			

TOTAL: \$255.00 X (2) STARTERS = \$510.00

## NOTES

- 1 Starter pricing based on Furnas brand class 14 magnetic motor starters with solid state overload.
- 2 Pricing shown for starter only. Price disconnect separately if necessary. Combination starter/disconnects are available, though disconnects are normally the responsibility of the electrical contractor.
- 3 Addition of a control transformer, though often required for interlock type applications, drives the price up considerably because of the need for a larger size enclosure.
- 4 For hazardous locations, a NEMA 7 & 9 enclosure is required. Pricing for this type of enclosure not shown here.
- 5 In applications requiring remote control of starter or interlock to other devices, inclusion of a control transformer and a selector switch will cover most scenarios.
- 6 In applications requiring nothing more than start/stop control at the starter, include start/stop pushbuttons (same price as selector switch).